

PCB DIMENSIONS (mm)	
A	86.5 x 33
B	57 x 32
C	42 x 32
D	34 x 59.6
E	40 x 33

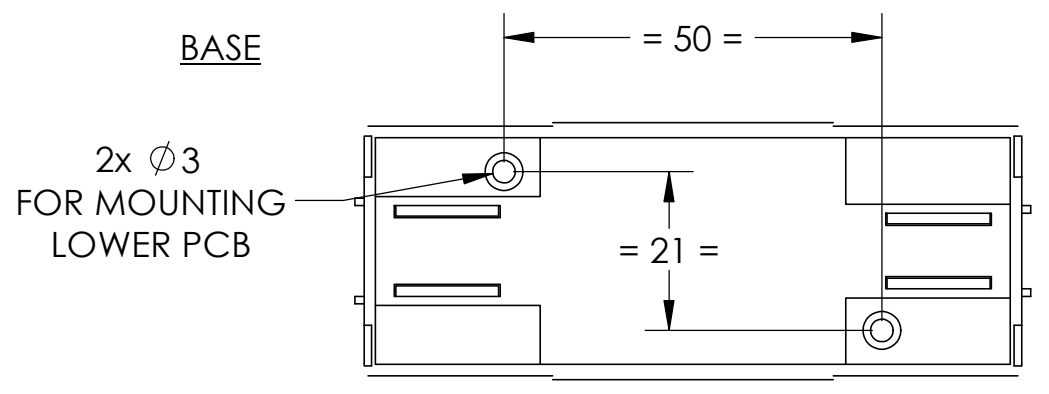

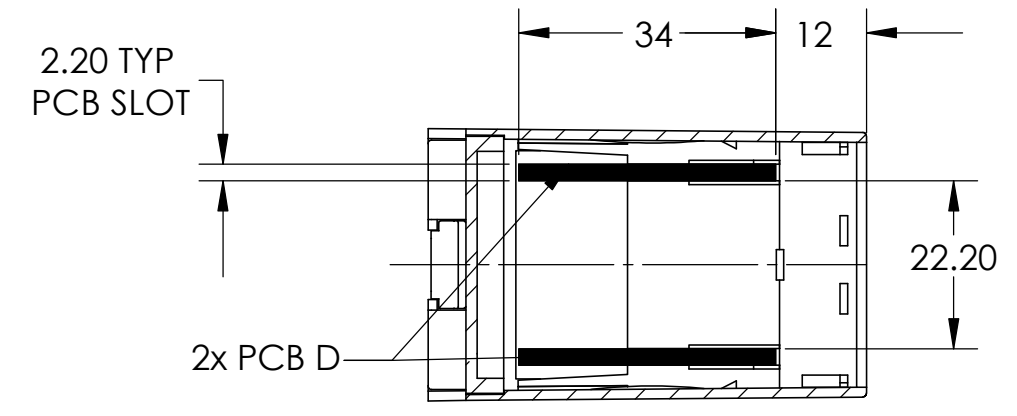

PCB DIMENSIONS (mm)	
A	86.5 x 50
B	57 x 49
C	42 x 49
D	34 x 59.6
E	40 x 50

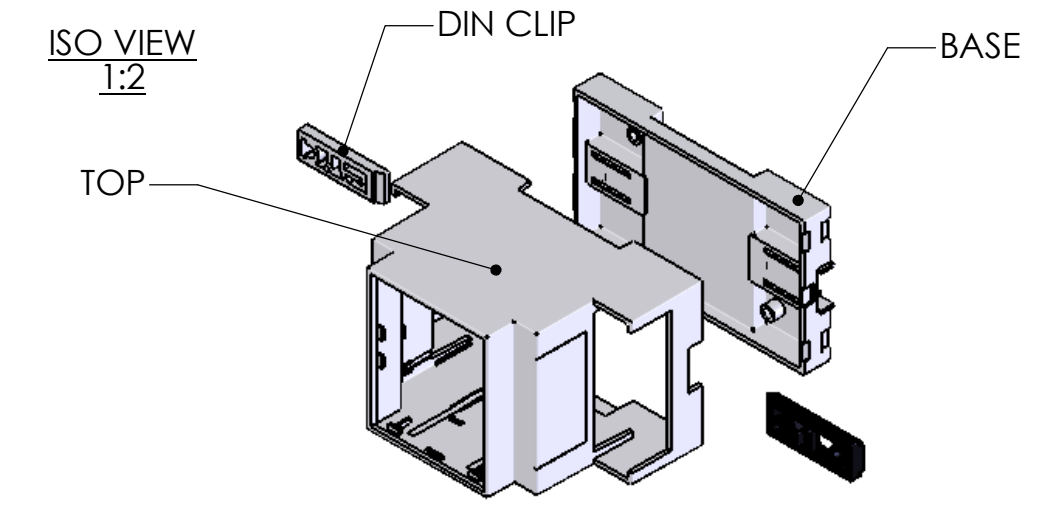
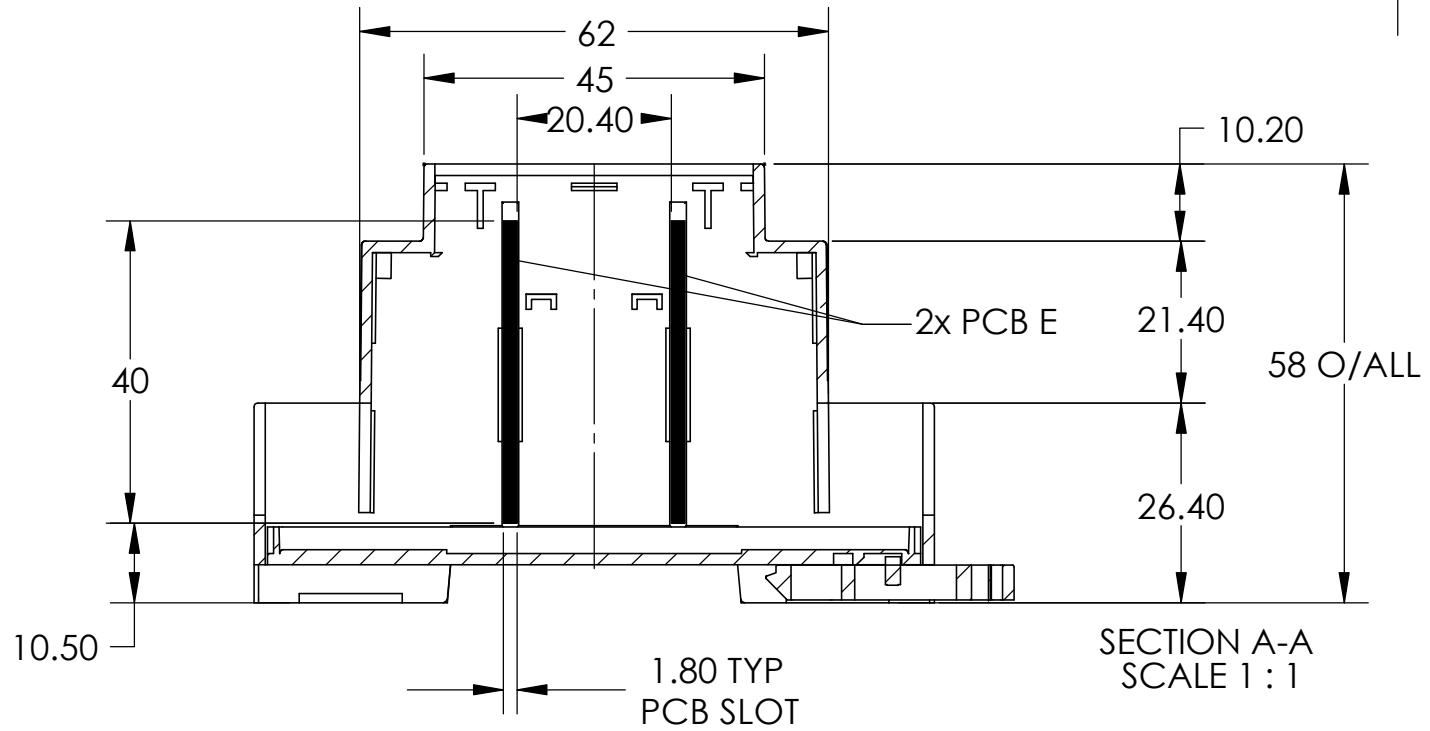
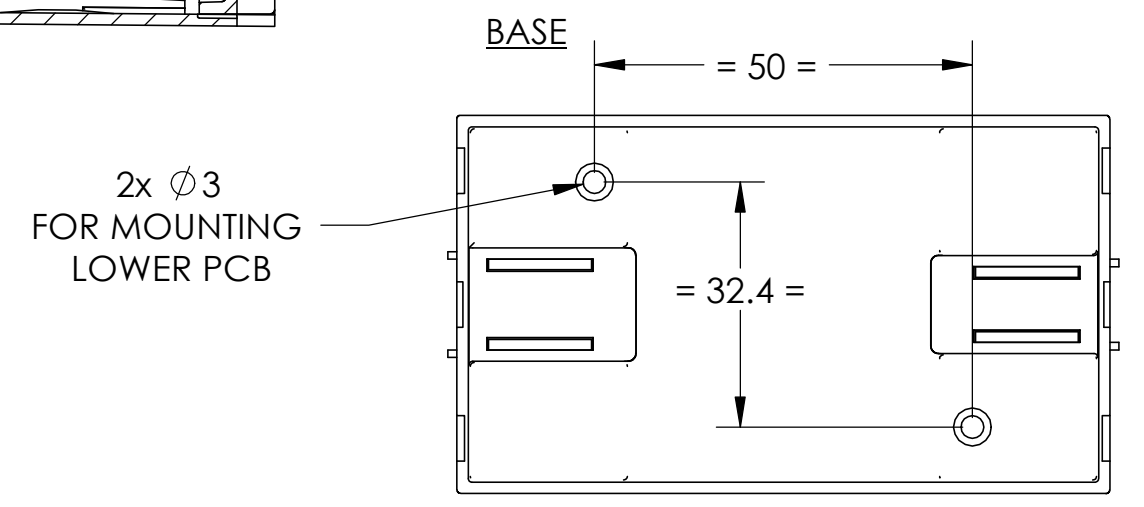
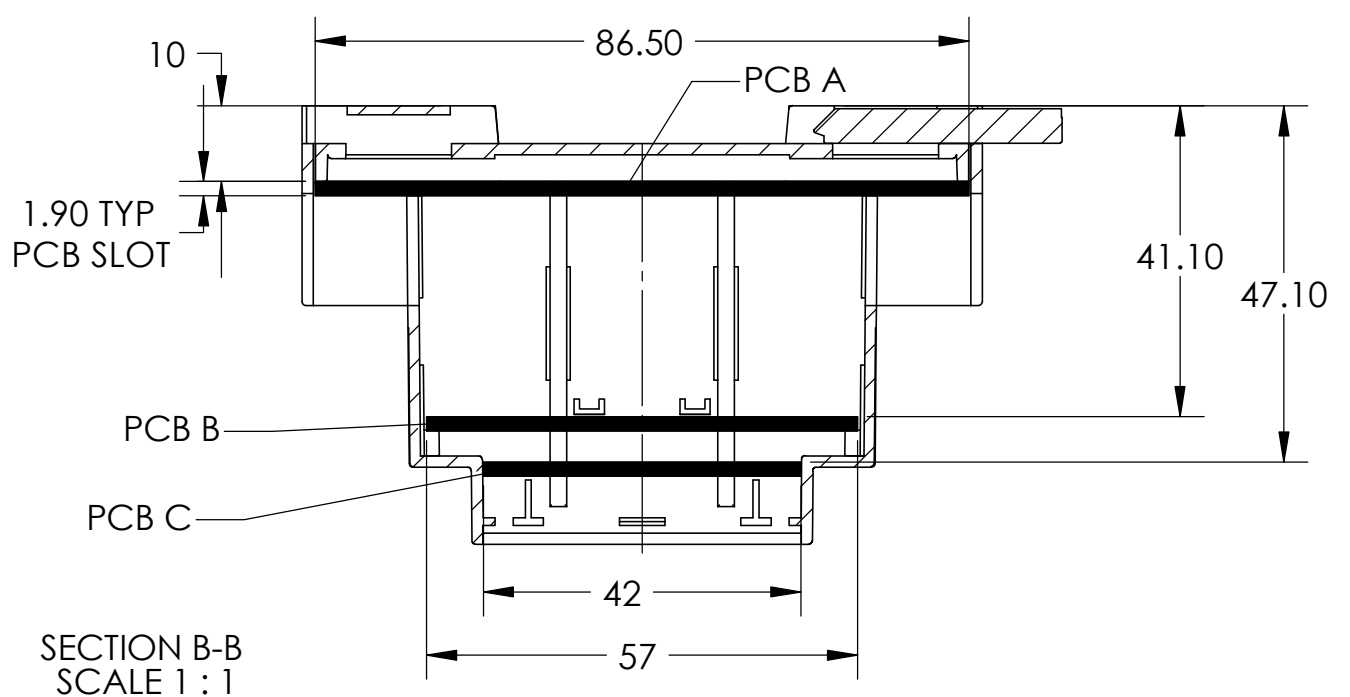
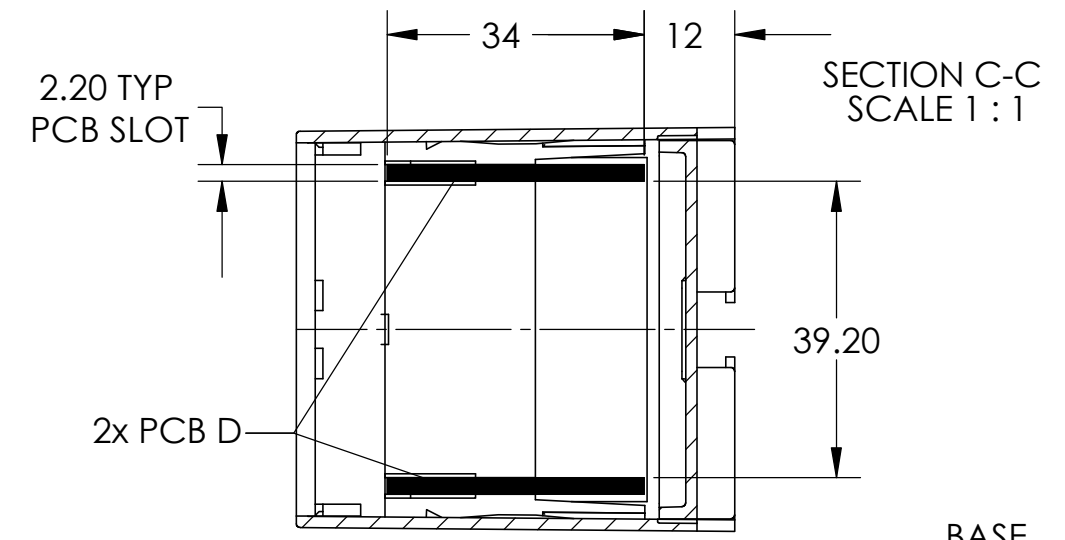
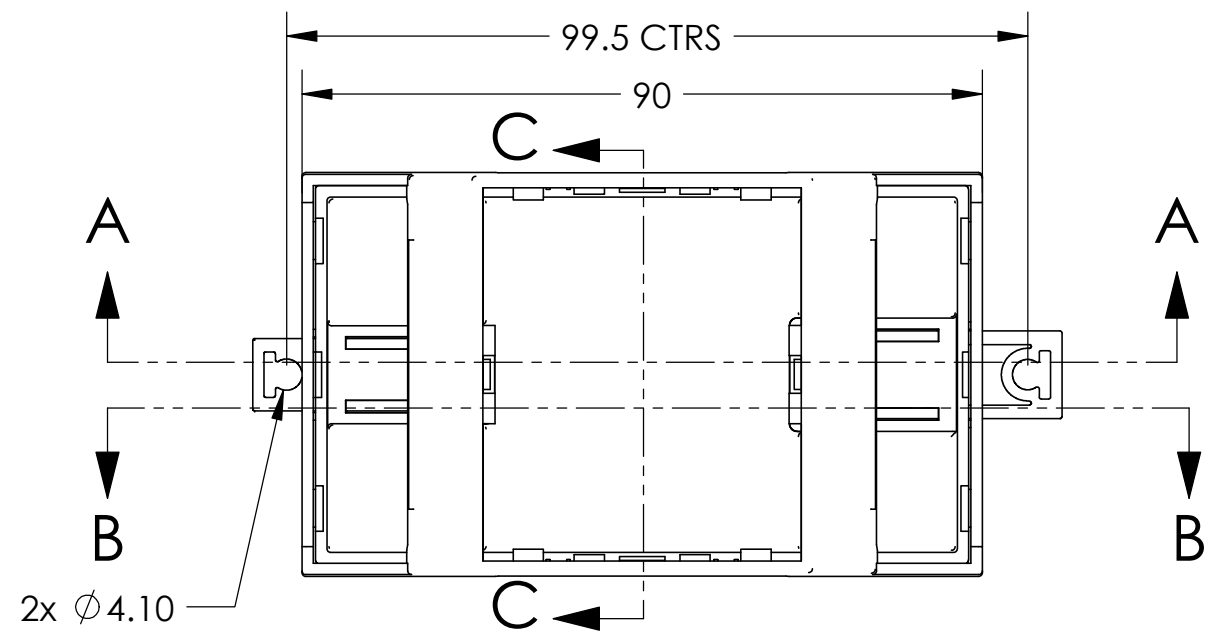

				DO NOT SCALE DRAWING		REVISION: 0	
				TITLE:			
				FINISH: SMOOTH			
				MATERIAL: UL94-VO PC		DWG NO.	
				PROJECTION:		SCALE: 1:1	
NAME	SIGNATURE	DATE		A3			
DRAWN		07/10/10					
CHK'D	LS	07/10/10		SHEET 1 OF 1			

**ASSEMBLY**

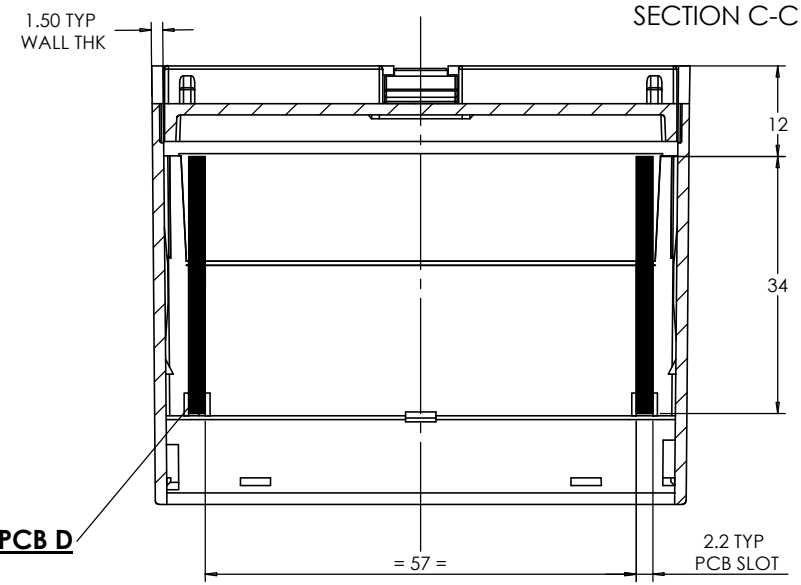
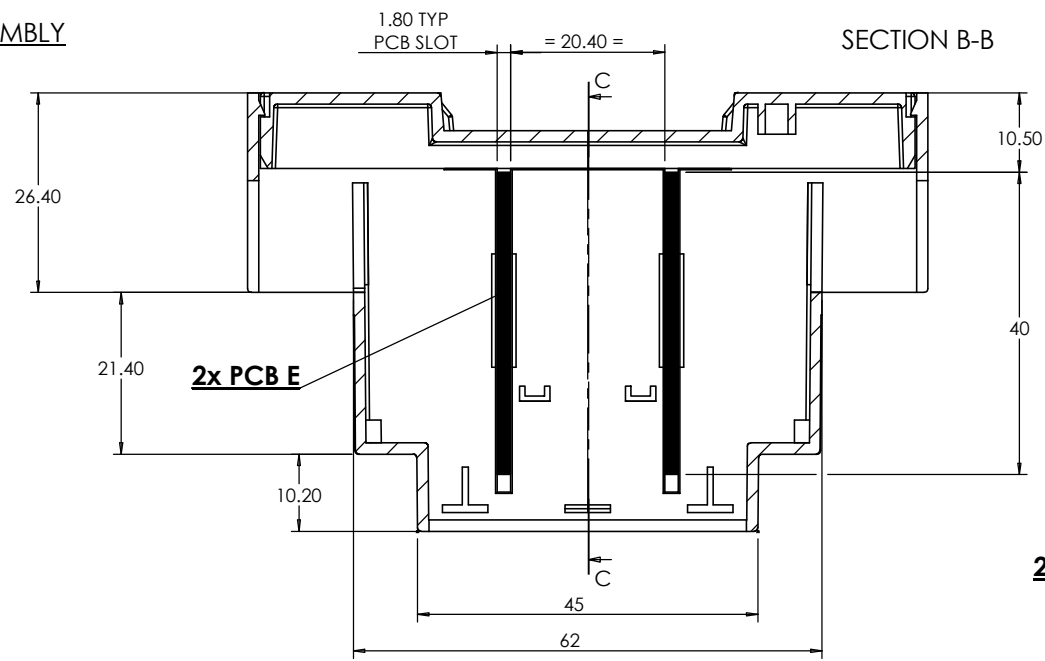

**BASE**

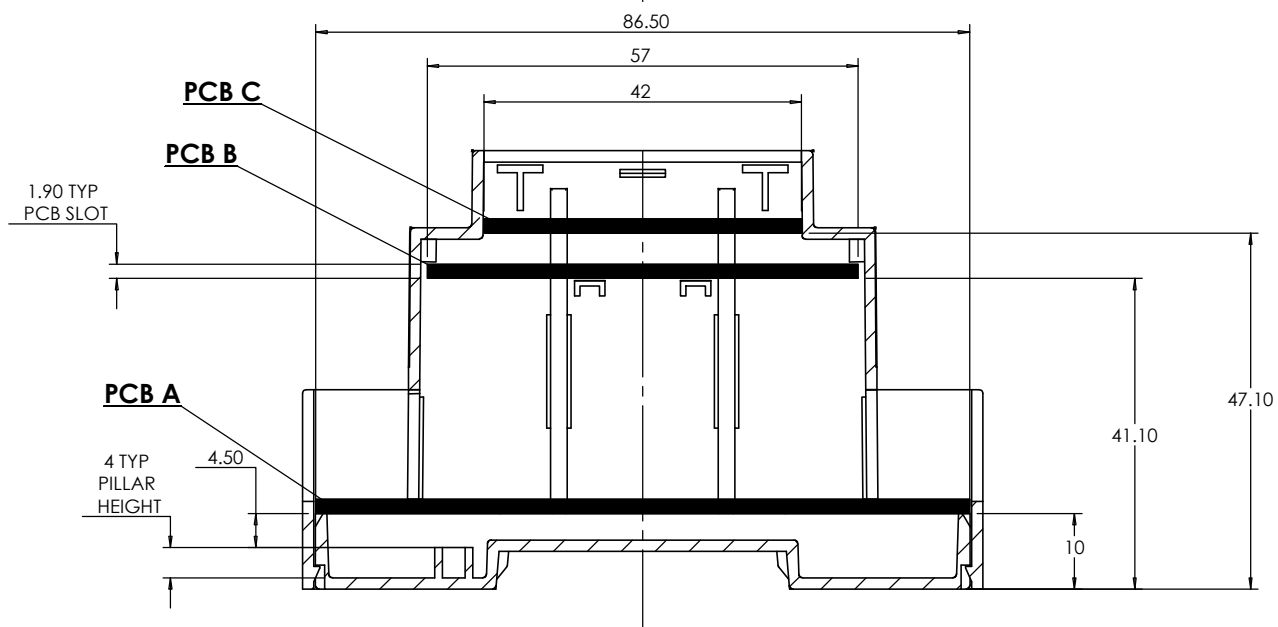
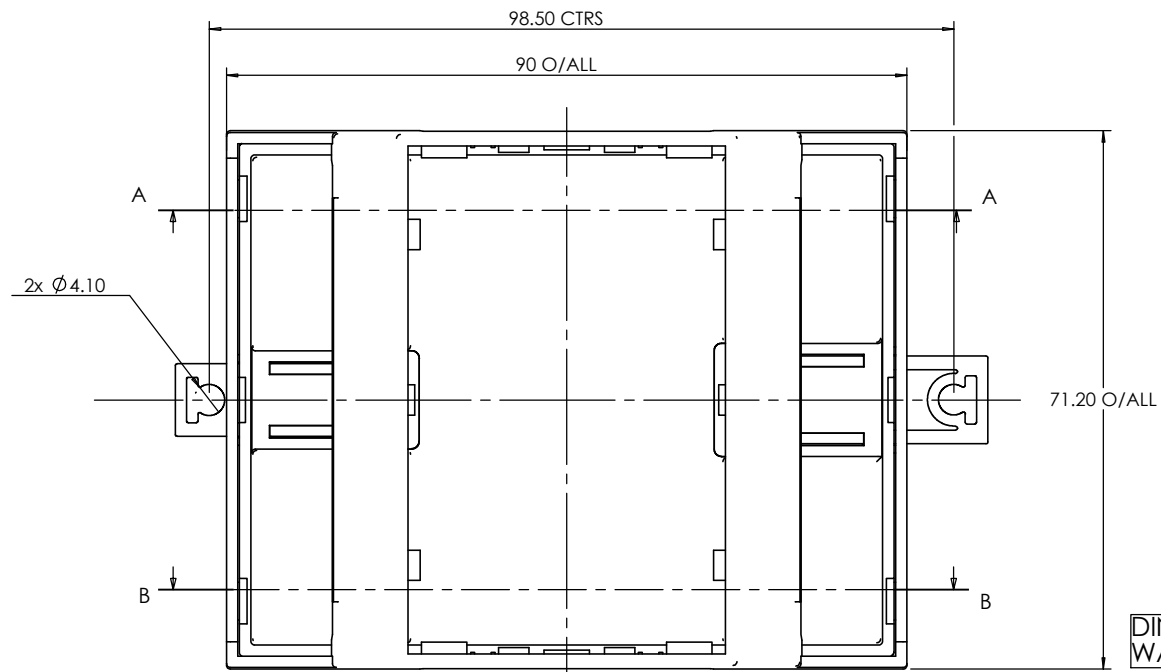
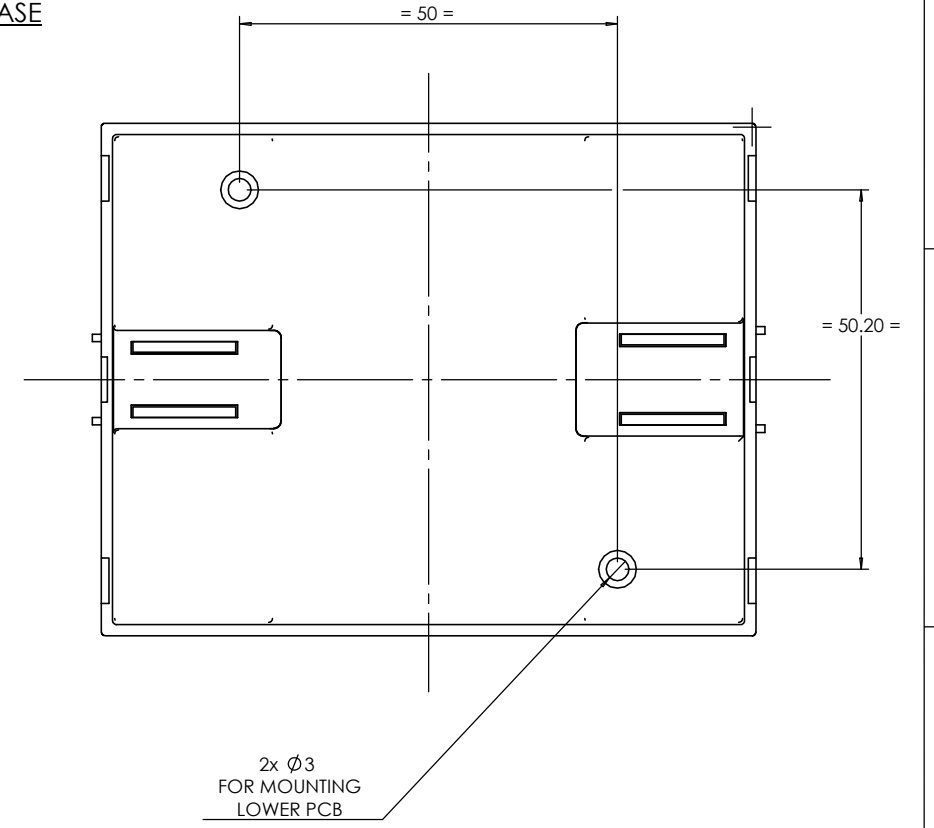

**ISO VIEW  
1:2**

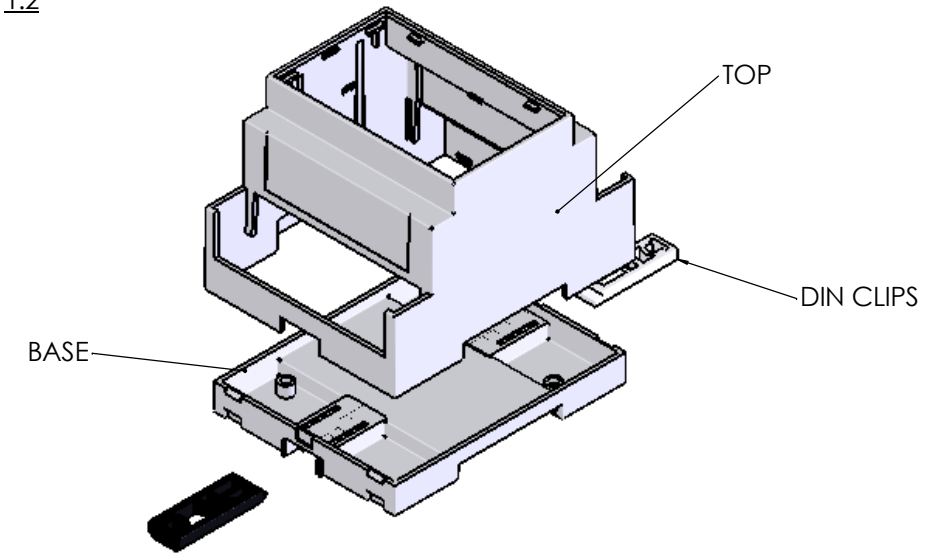

PCB DIMENSIONS (mm)	
A	86.5 x 68
B	57 x 67
C	42 x 67
D	34 x 59.6
E	40 x 68

**ASSEMBLY**

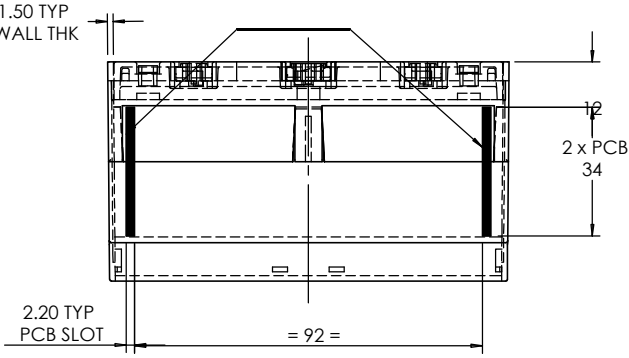
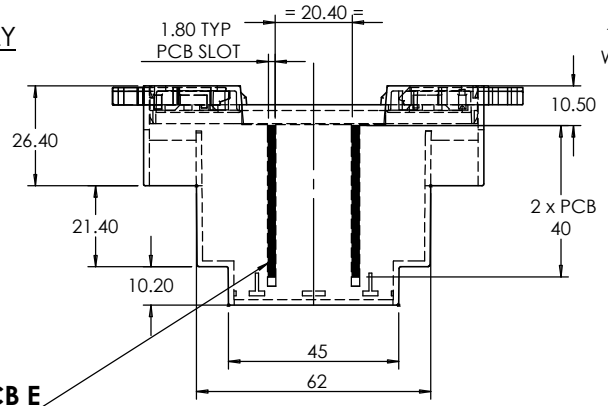

**BASE**

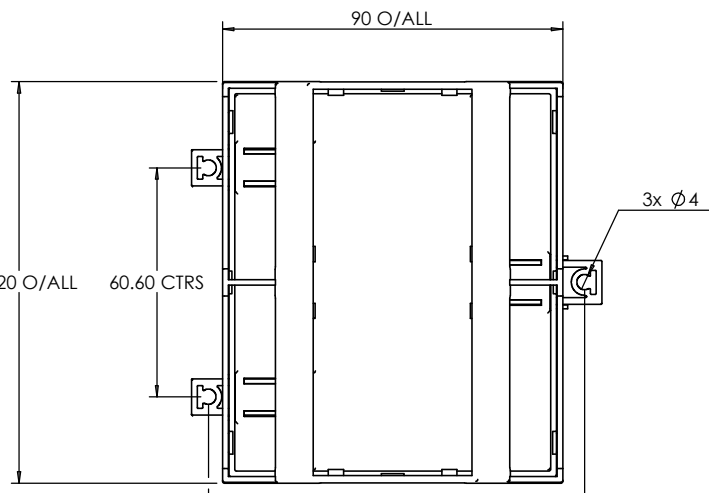
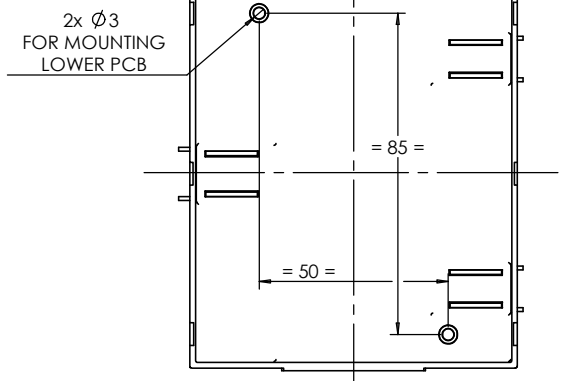

DIN CLIPS ARE SHOWN IN WALL MOUNTING POSITION

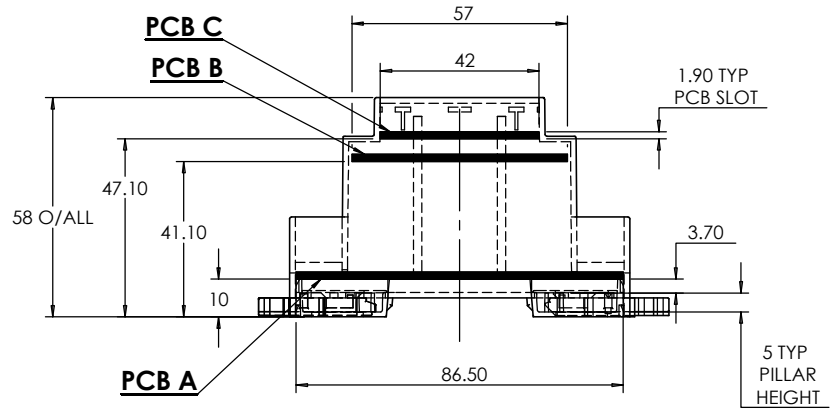

**ISO VIEW  
1:2**

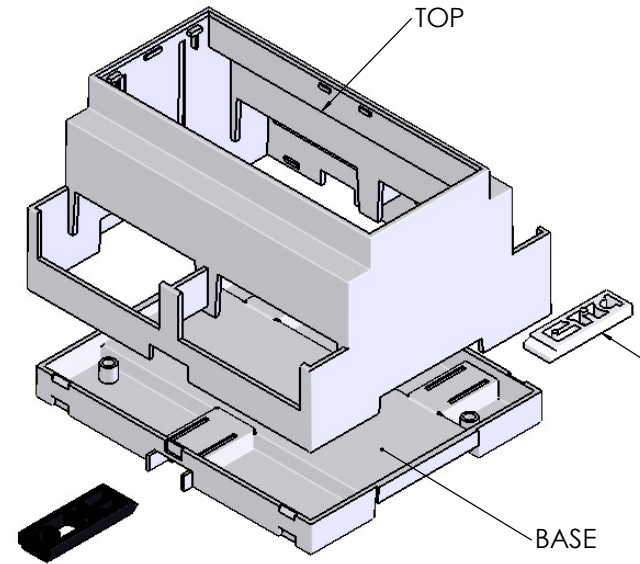

PCB DIMENSIONS (mm)		
<b>A</b>	86.5	x 103
<b>B</b>	57	x 102
<b>C</b>	42	x 102
<b>D</b>	34	x 59.6
<b>E</b>	40	x 103

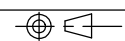
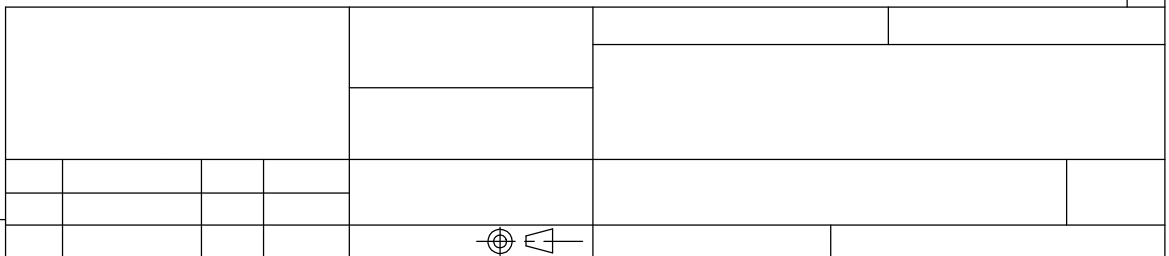

**ASSEMBLY**

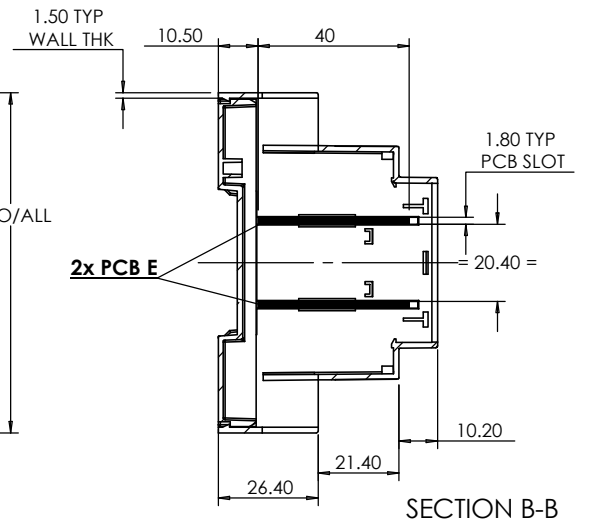
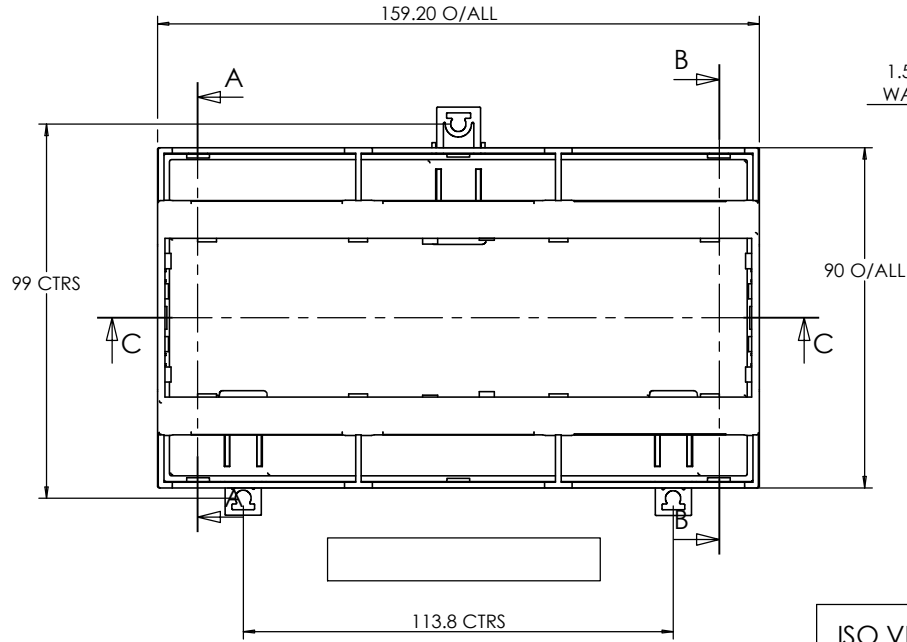
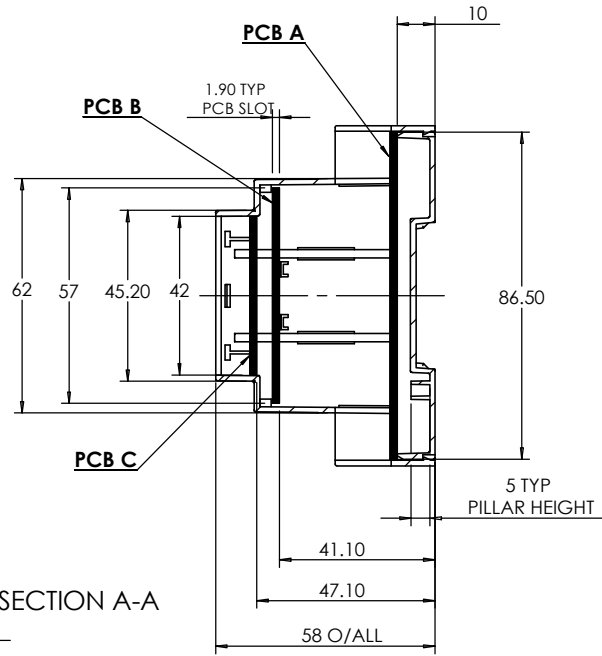

**BASE**

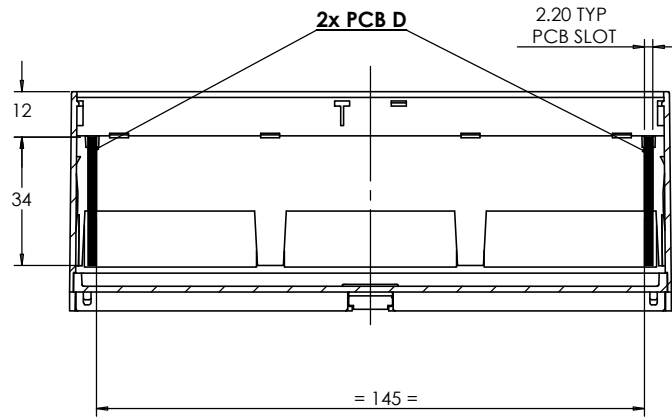
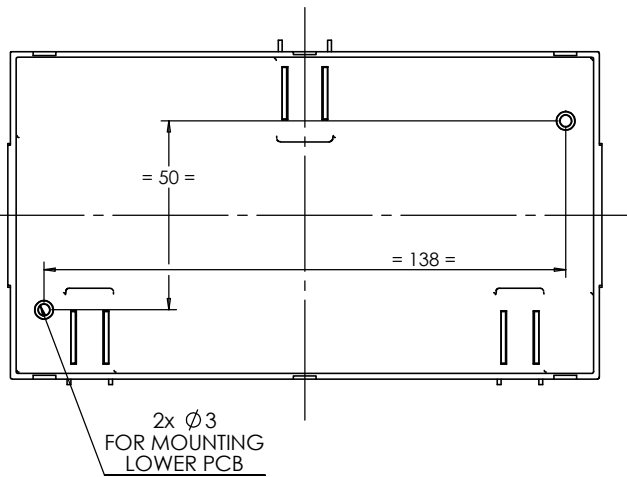

**ISO VIEW  
1:4**

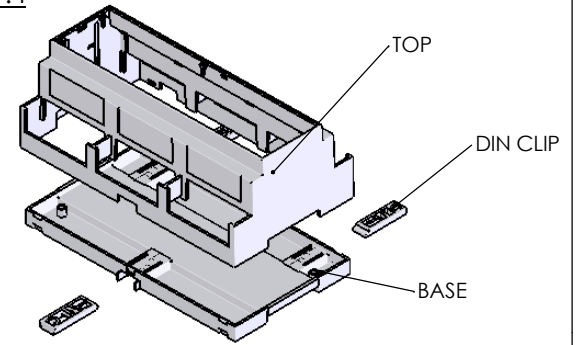

PCB DIMENSIONS (mm)	
A	86.5 x 155
B	57 x 155.4
C	42 x 154
D	34 x 59.6
E	40 x 155

